

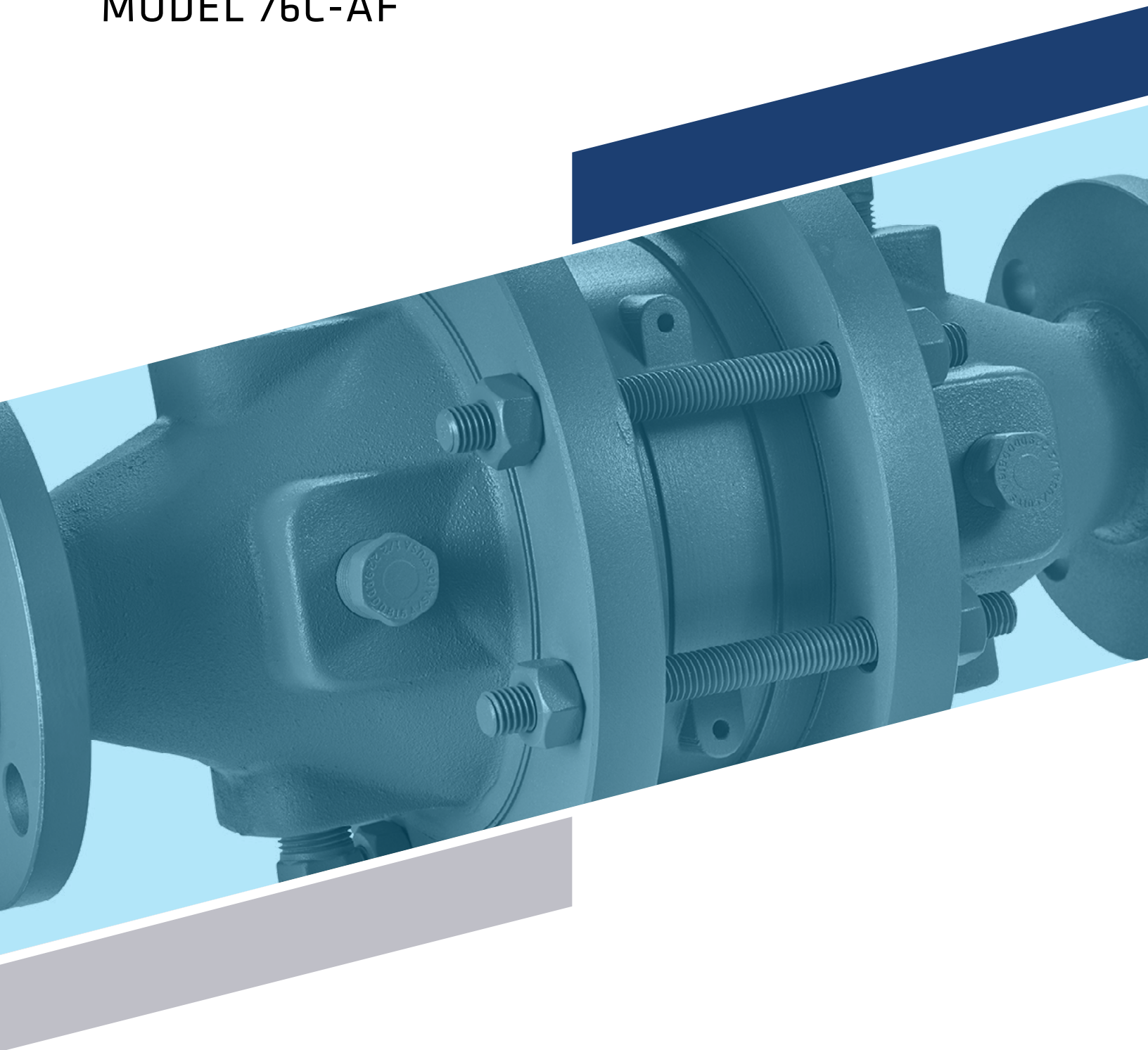

FLAME ARRESTER

MODEL 76C-AF



MODEL 76C-AF

The Groth Model 76C-AF is designed to inhibit flame propagation in gas piping systems and to protect low pressure tanks containing flammable liquids. Arresters protect low flash point liquids from external sources of ignition providing increased fire protection and safety.

Technical Details

- Connection Sizes: 2" through 12" 150# ASME Flanged Connection, DIN bolting available
- Housing standard material: Carbon Steel, Stainless Steel
- Bases standard material: Aluminum (2"-6"), Carbon Steel, Stainless Steel
- Flame element standard material: 316 Stainless Steel
- Operational Temperature Range: -4 to 140°F (-20 to 60°C)
- Gas Group: IEC IIA, NEC D
- Maximum Operational Pressure: see charts and IOM
- Burn Time: t_{BT} short-time burn rating
- Certified to ATEX Directive in compliance with EN ISO 16852:2016
- Thermocouple is required for flame detection per the ATEX code

Features

- Flame arrester element geometry maximizes flame quenching capability while minimizing pressure drop
- Removable element housing for ease of maintenance
- Spiral-wound, crimped ribbon flame element
- Flame elements made standard with premium 316SS material, reducing corrosion
- Bi-directional with respect to flow and ignition source

Options

- Exterior painting or coating available
- Drains and instrumentation ports available
- Available factory installed thermocouples for flame sensing



SPECIFICATIONS

Connection Size 150# ASME	Housing Nominal Size	A Width	B Height ± 1.0"		Approx Ship. Wt. Lbs. (kg) Carbon Steel Bases	Approx Ship. Wt. Lbs. (kg) Aluminum Bases
Inches (Nominal mm)	Inches (Nominal mm)	Inches (mm)	CS/SS Base Material inches (mm)	AL Base Material inches (mm)		
2 (50.8)	6 (152.4)	9.2 (233.68)	16 (406.4)	16.5 (419.1)	63 (29)	32 (15)
3 (76.2)	8 (203.2)	11.2 (284.48)	16 (406.4)	16.5 (419.1)	111 (50)	64 (29)
4 (101.6)	10 (254)	13.2 (335.28)	16 (406.4)	16.5 (419.1)	132 (60)	68 (31)
6 (152.4)	16 (406.4)	20 (508)	21 (533.4)	21.5 (546.1)	298 (135)	181 (82)
8 (200)	20 (500)	23.5 (597)	33 (838)	n/a	538 (244)	n/a
10 (250)	24 (600)	27.1 (688)	38.0 (965)	n/a	772 (350)	n/a
12 (300)	28 (700)	32.3 (820)	41.0 (1041)	n/a	1120 (508)	n/a

Specifications subject to change without notice. Certified dimensions available upon request.

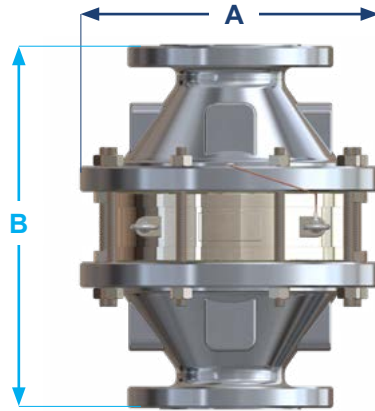

For an arrester to be properly applied, the following configuration scenario must be met:

ATEX Straight Pipe, Closed End Configuration:

Connection Size x Housing Size	Gas Group	End Condition	Maximum Pipe Length from Ignition Source to Flame Arrestor	Maximum Operational Pressure	Allowable Bend(s)*	Maximum Burn Time at Atmospheric Pressure	Operational Temperature Range °F (°C)
2" x 6" thru 12" x 28"	IIA (D)	Closed or Open End	50 pipe diameters	17.4 psia (1.2 bara) or better, see IOM	None	Short-time burn rating (1 minute)	-4 to 140 (-20 to 60)

ATEX Straight Pipe, Allowable Installation Configuration

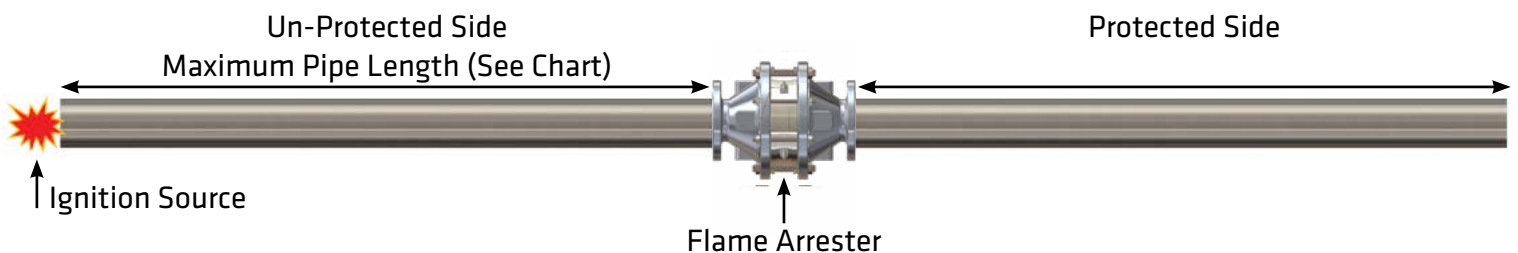

FLOW CAPACITY

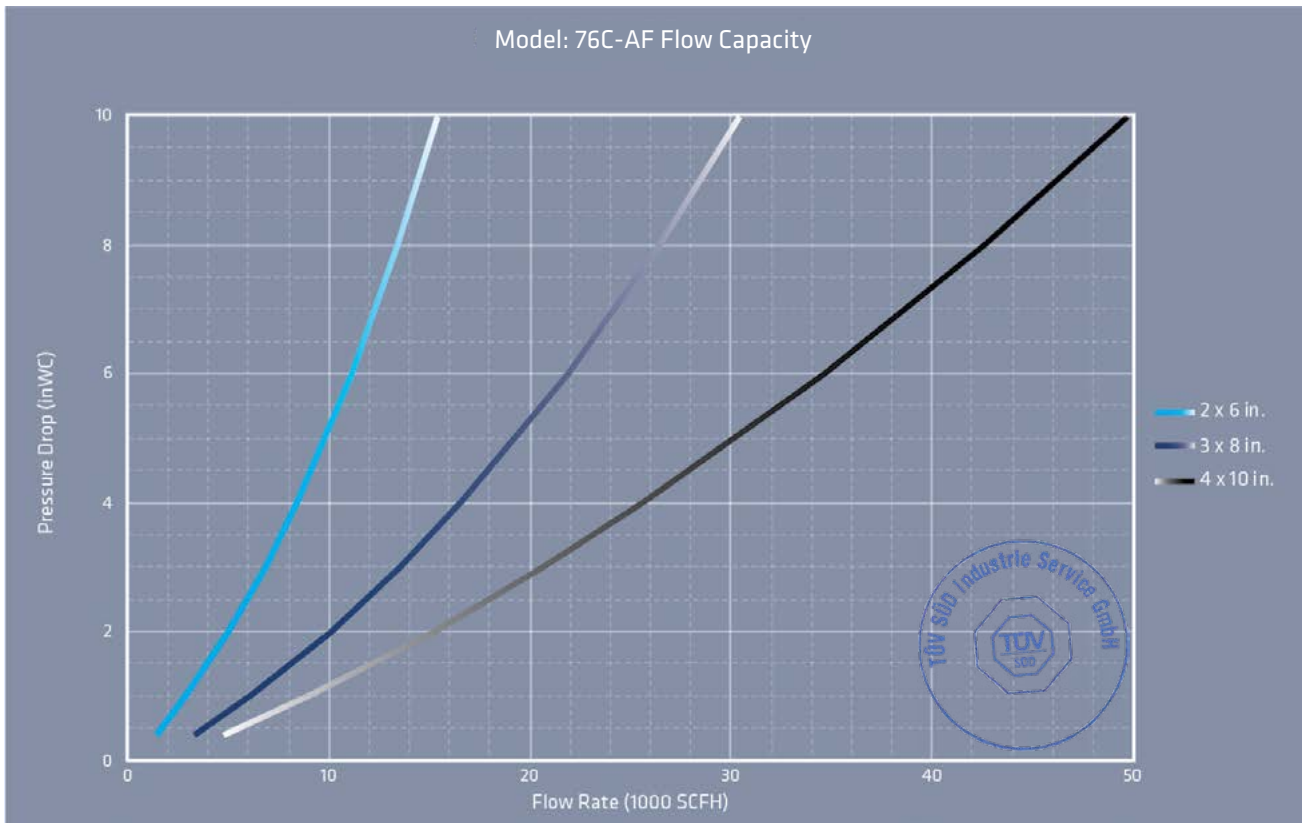
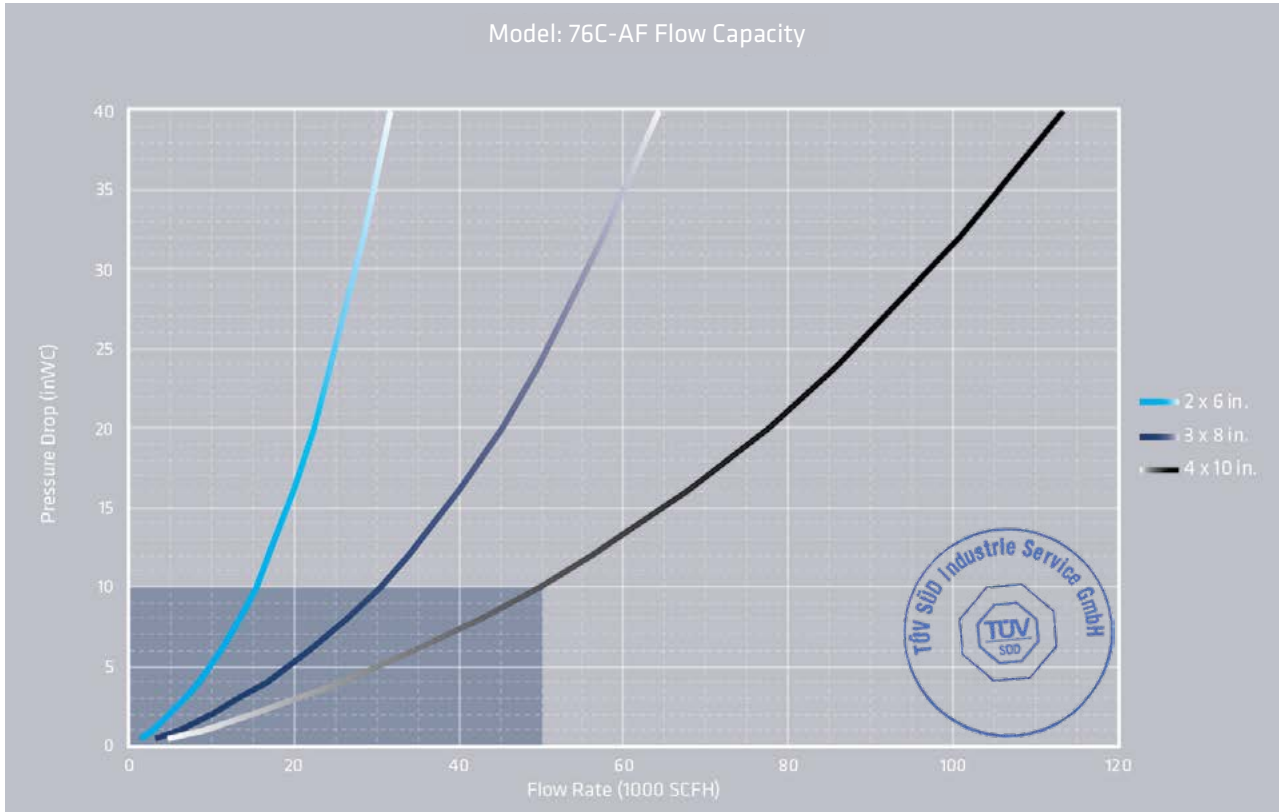

The test equipment, procedures, and reporting methods utilized by Groth Corporation meet the requirements of standards API 2000/ISO 28300 and ISO 16852. The equipment, methods, and results have been reviewed and certified by TÜV SÜD.

Flow data are for in-line mounting and does not include entrance losses or exit losses.

Flow values based on air at 60°F venting to atmospheric pressure of 14.6959 psia.

FLOW CAPACITY

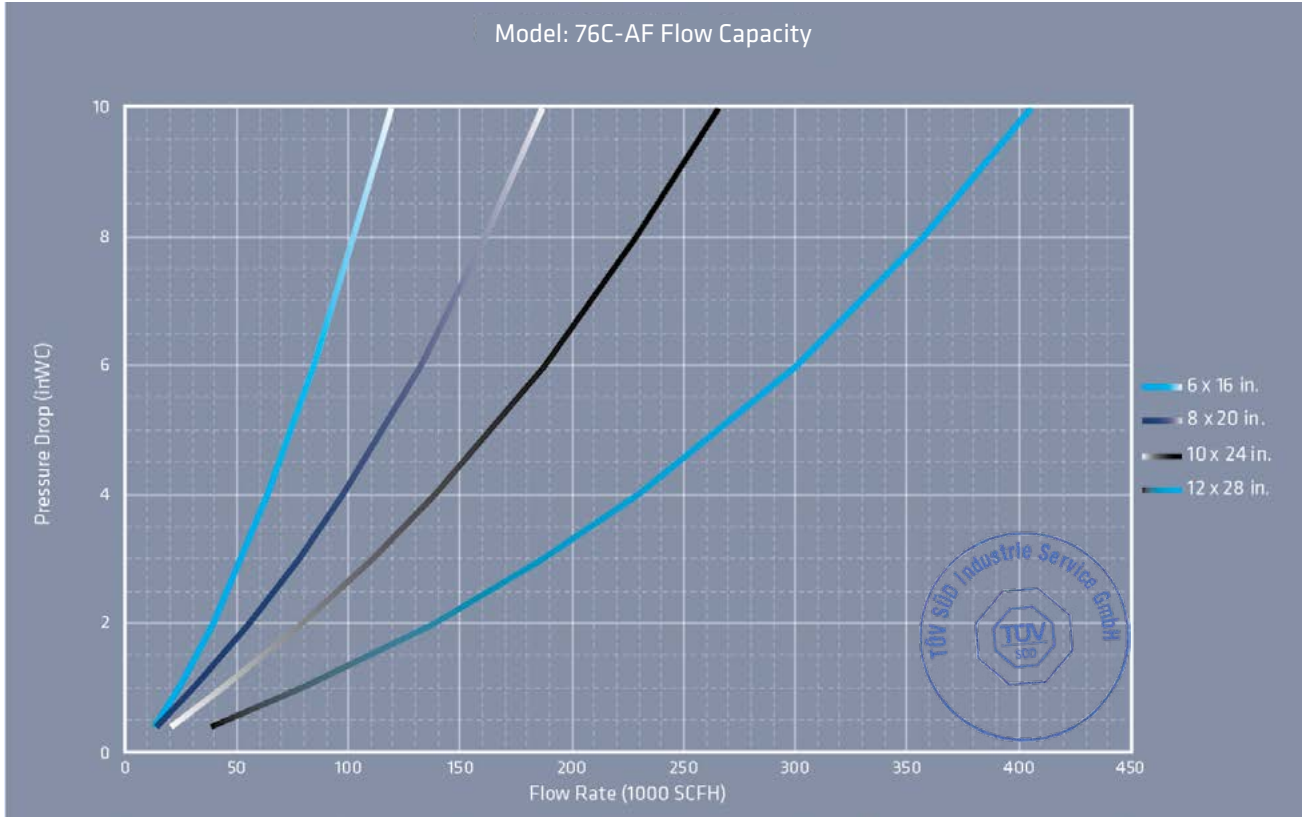
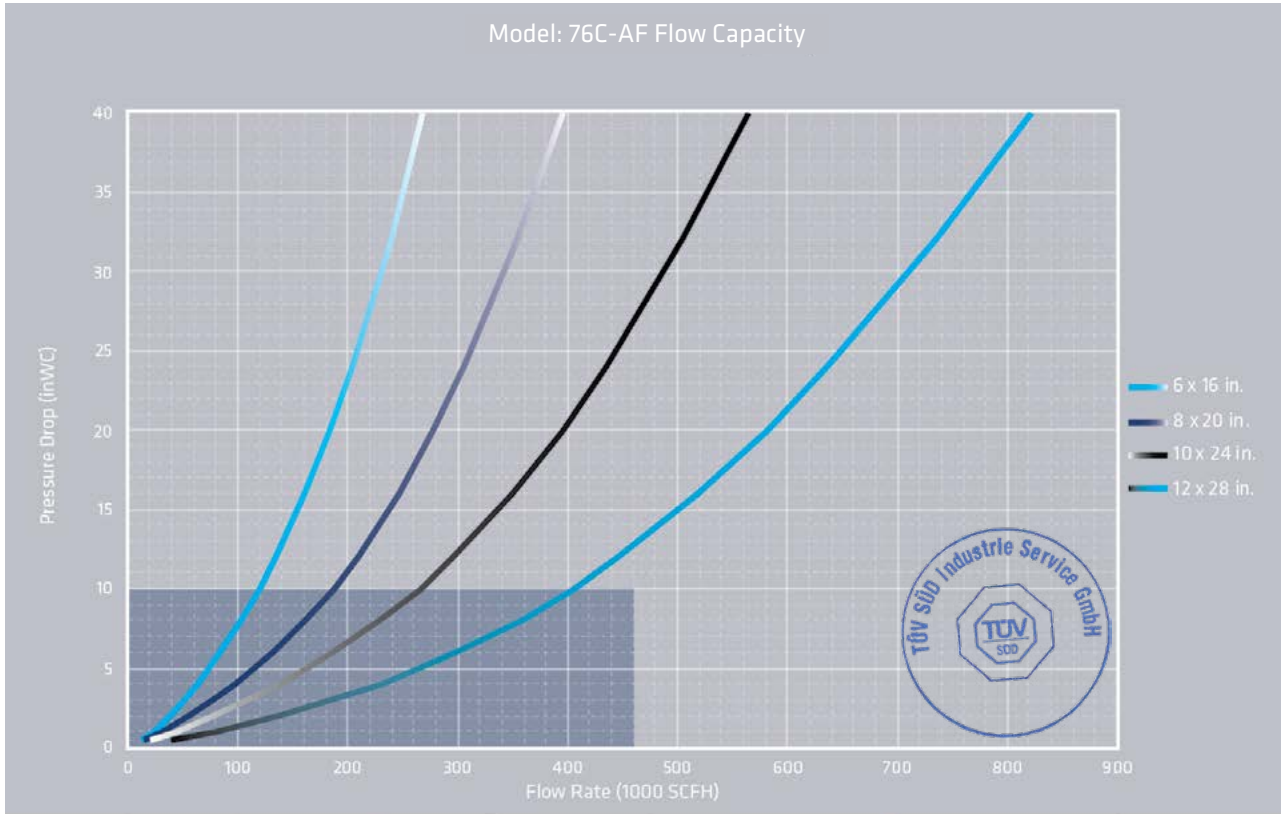

The test equipment, procedures, and reporting methods utilized by Groth Corporation meet the requirements of standards API 2000/ISO 28300 and ISO 16852. The equipment, methods, and results have been reviewed and certified by TÜV SÜD.

Flow data are for in-line mounting and does not include entrance losses or exit losses.

Flow values based on air at 60°F venting to atmospheric pressure of 14.6959 psia.

FLOW CAPACITY

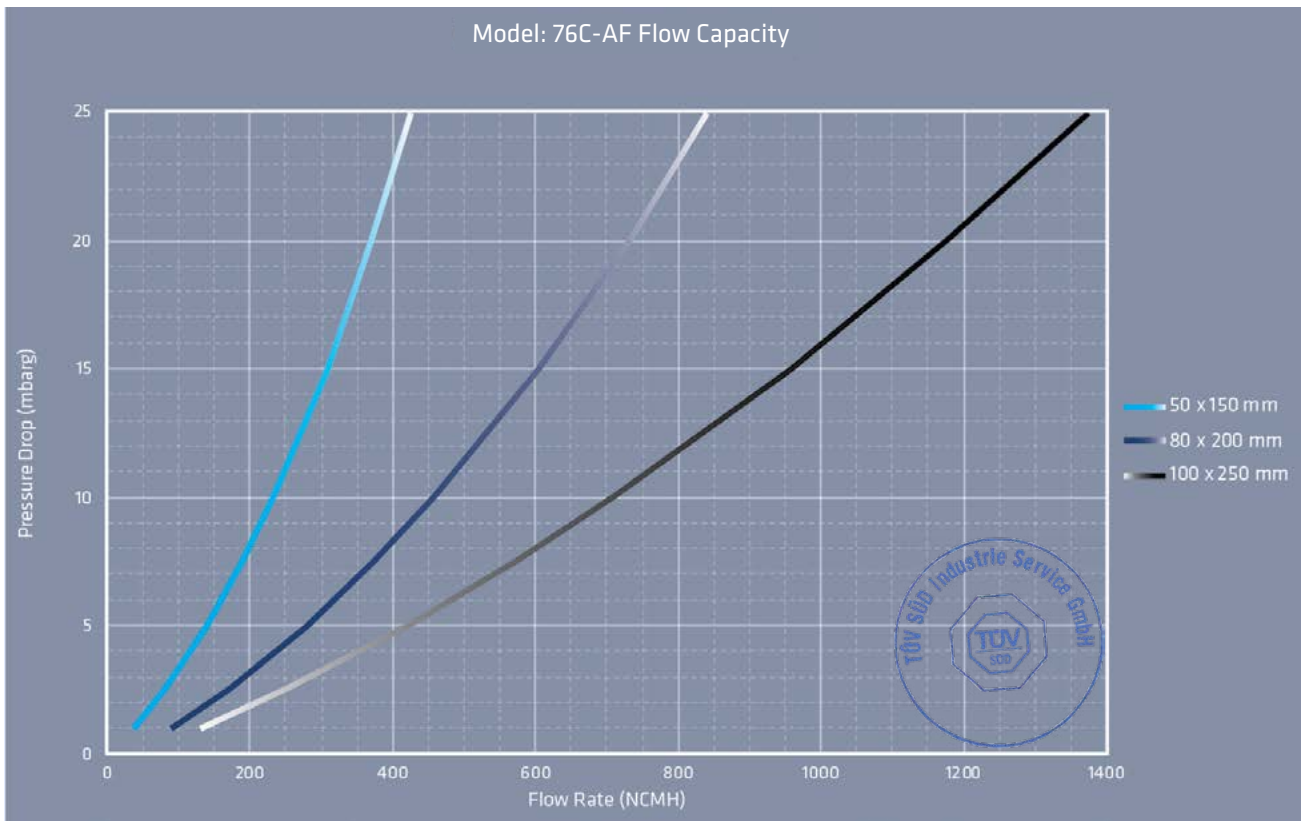
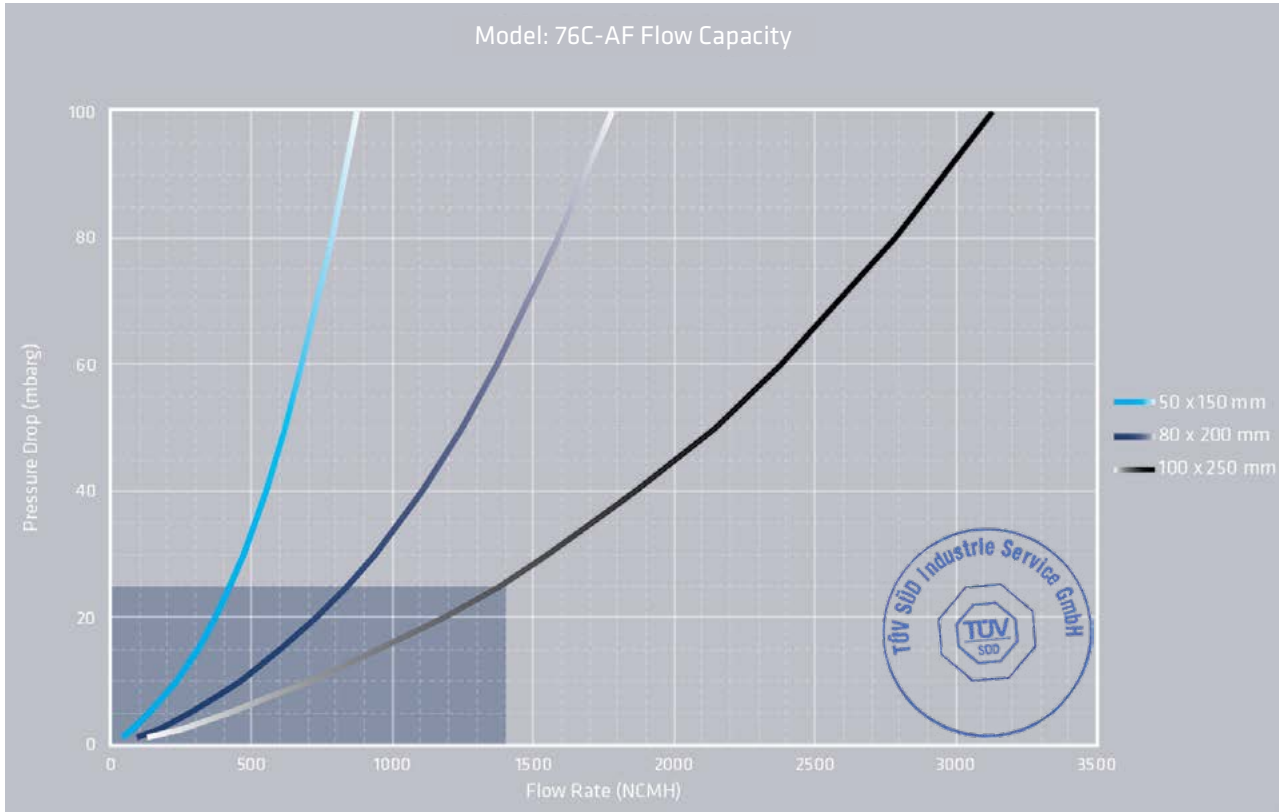

The test equipment, procedures, and reporting methods utilized by Groth Corporation meet the requirements of standards API 2000/ISO 28300 and ISO 16852. The equipment, methods and results have been reviewed and certified by TÜV SÜD.

Flow data are for in-line mounting and does not include entrance losses or exit losses.

Flow values based on air at 0°C venting to atmospheric pressure of 1.01325 bara.

FLOW CAPACITY

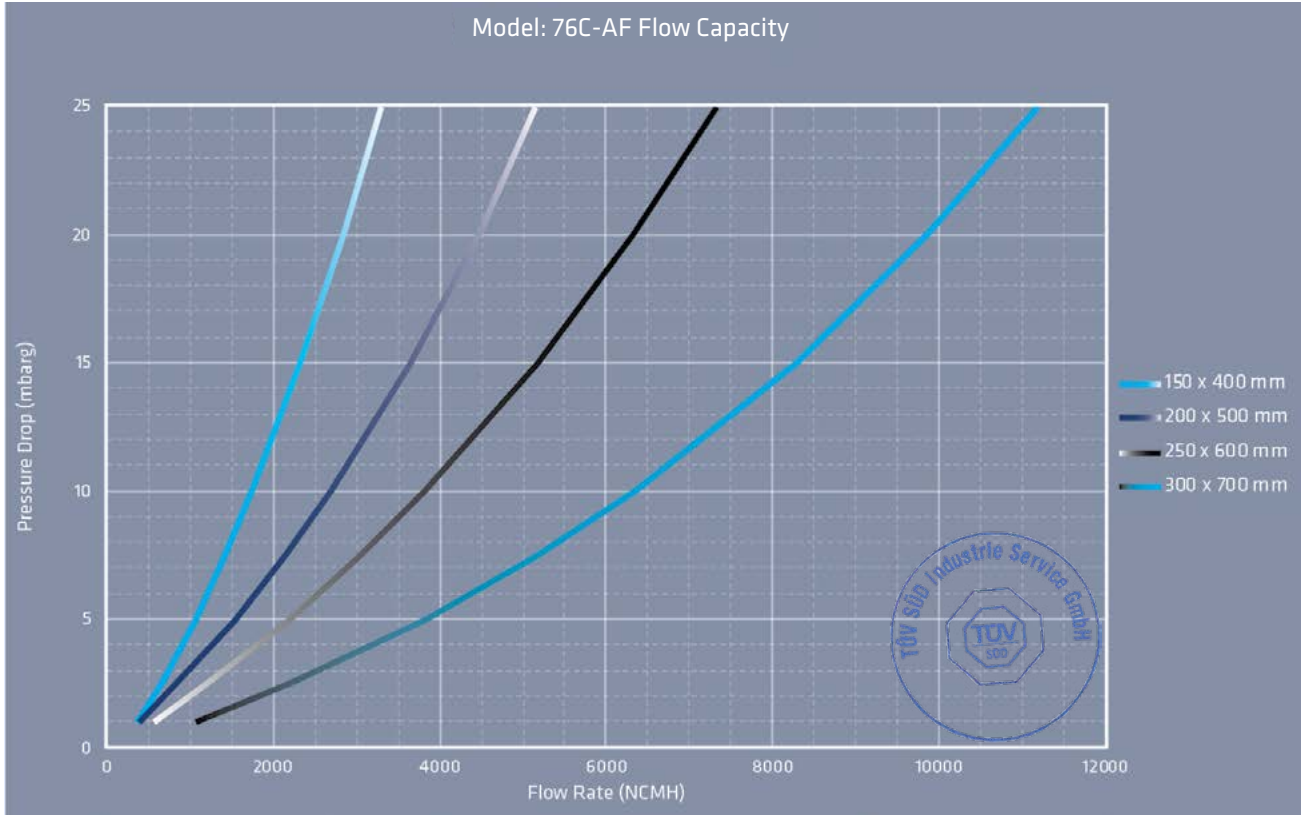
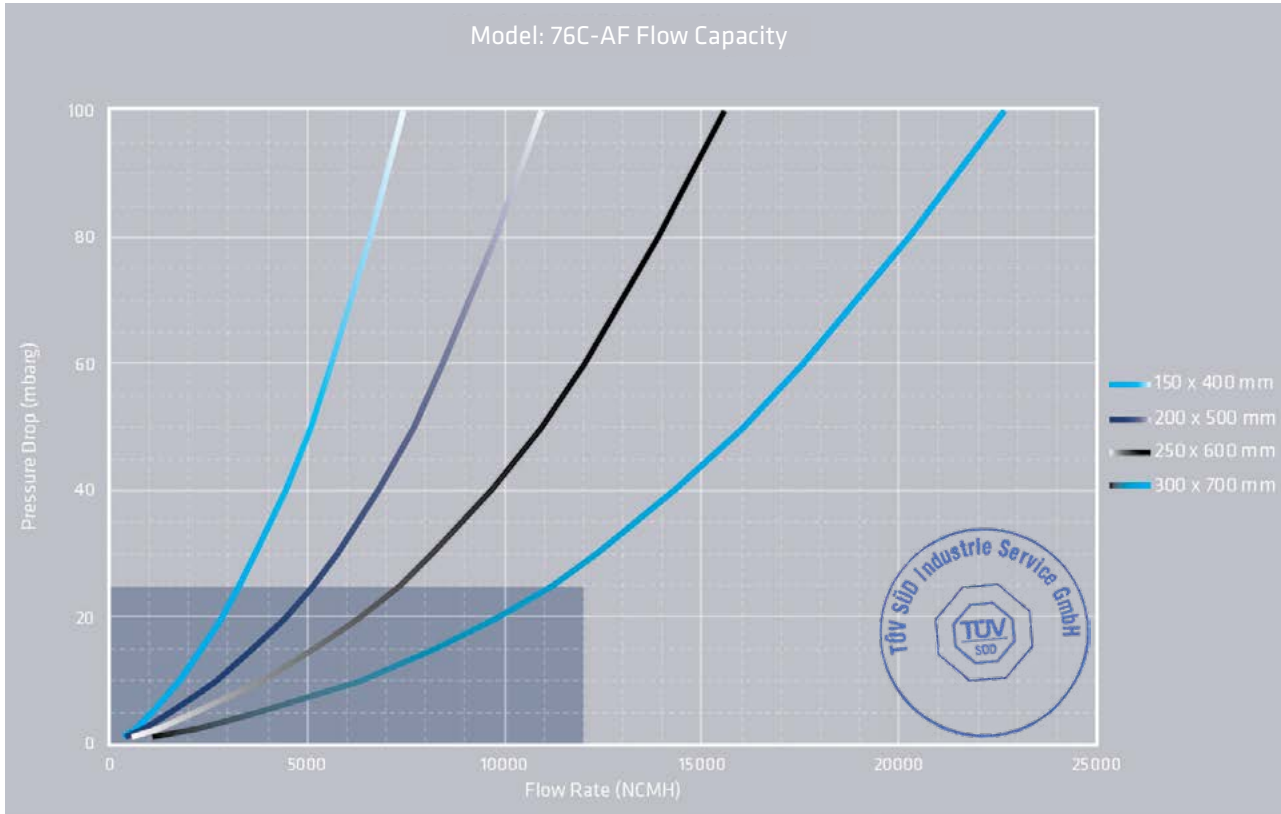

The test equipment, procedures, and reporting methods utilized by Groth Corporation meet the requirements of standards API 2000/ISO 28300 and ISO 16852. The equipment, methods and results have been reviewed and certified by TÜV SÜD.

Flow data are for in-line mounting and does not include entrance losses or exit losses.

Flow values based on air at 0°C venting to atmospheric pressure of 1.01325 bara.

HOW TO ORDER

For easy ordering, select proper model numbers

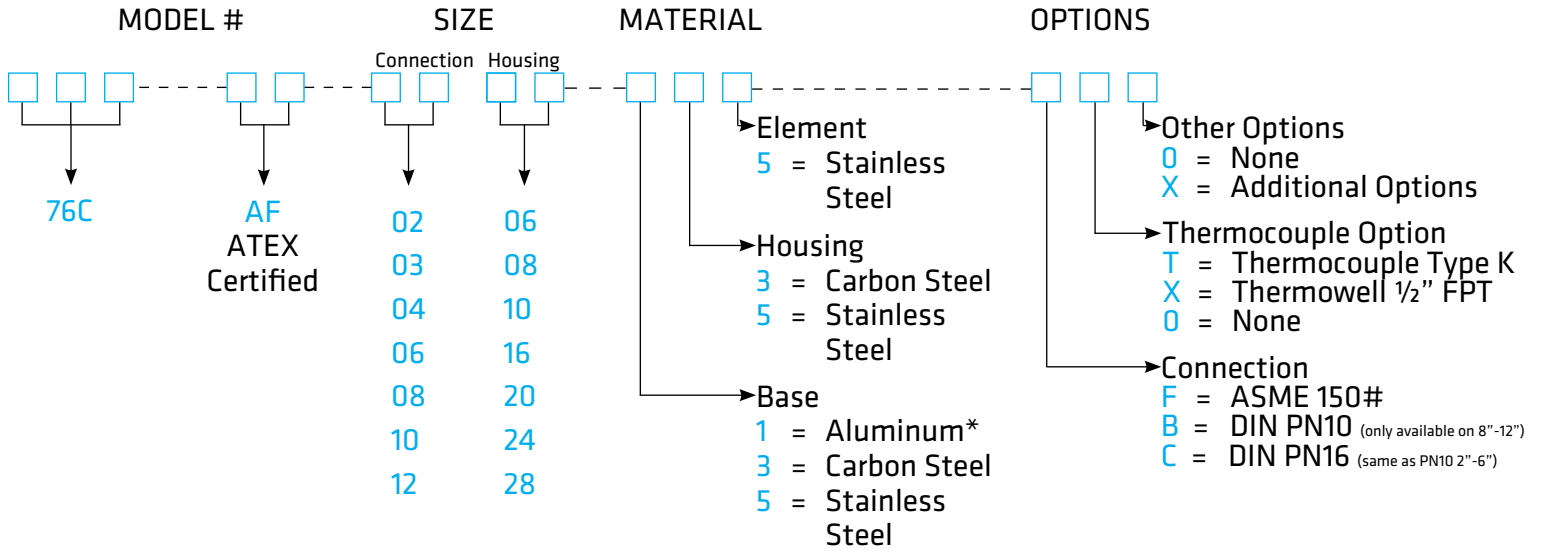

Notes

- Include model number and setting when ordering
- For special options, consult factory
- *Aluminum base material is only available in connection sizes 2" through 6"

Example

7 6 C - A F - 0 2 0 6 - 3 3 5 - F T 0

Indicates a 2" x 6" Model 76C-AF, ATEX Certified, with carbon steel bases, carbon steel housing, 316SS element, 150# ASME bolting, a thermocouple Type K and no other options.



GROTHCORP.COM